

Performance of protection systems whilst the network is under stress: Case Studies from Northern Regional Power Systems of India

AGRAWAL V.K., PORWAL RAJIV, KUMAR RAJESH., PANDEY V.
(Power System Operation Corporation Limited)
(A wholly owned subsidiary of Power Grid Corporation of India Limited)
India

Summary

This paper presents few case studies that could be referred to examine the performance of the protective system under different operating conditions. For the purpose of discussion the operating conditions that have been considered in the paper are - large generation loss, large load throw off; cascade failure; system restoration; and extreme weather conditions. The case studies have been developed from typical grid events that have occurred in the Northern Regional power system of India. The paper discusses the challenges in protection coordination in developing grids and proposes harmonization of protection philosophy within a synchronous system, sharing of information between utilities, periodic audit of the protection system and inclusion of protective system performance indices in the regulatory norms for utilities in order to minimize protection system misoperations.

Keywords

Grid events, Blackout, Blackstart, Protection performance, Protection audit

1. Introduction

The Northern Regional (NR) grid is the largest among the five regional grids in India. NR is spread over more than 1 million square kilometres (31% of India) and serves a population exceeding 368 million people (30 % of India). It has an installed generation capacity of 47 GW (27 % of All India capacity). In the year 2010-11 the peak demand met of NR was 34 GW while the annual energy consumption was 239 BU. There are 12 transmission utilities and more than 170 generating stations connected at a voltage level of 132 kV and above. The highest operating voltage in NR grid is 400 kV in AC transmission and ± 500 kV in DC transmission.

Within the NR grid the major coal pithead thermal power stations are located in the extreme South-eastern part while the snow fed hydro power stations are located in the Himalayas in the North western part of the grid. However, the major load centres are located in the central and western part of the grid. Therefore large EHV transmission lines network with long 400 kV transmission lines exists for connecting the generation pockets with the load centres. The transmission network passes through diverse terrain that comprises of tropical forests, high rise mountains, indo-gangetic plains, deserts and thickly populated cities. As a result, the operation and maintenance of these lines is quite challenging.

The operation of the entire Northern Regional grid is co-ordinated in real time by the Northern Regional Load Despatch Centre (NRLDC) in close association with the eight State

Load Despatch Centres (SLDCs). At the regional level there are coordination committees to discuss various technical and commercial issues related to grid operation, protection, energy settlement, data acquisition & communication. The forced outage of transmission elements and grid incidents/disturbances are reported, discussed in the Protection Coordination sub-committee and at various other forums [1]. The typical ones are also investigated in greater detail by an expert group constituted from among the regional constituents. The general philosophy of protection and incidents reporting is given in [1, 2]. The case studies in this paper are based on the grid incidents that occurred in the Northern Region during the last few years.

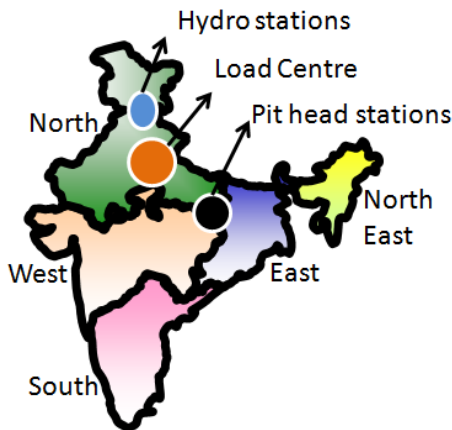

Figure 1.1: Regional grids in India

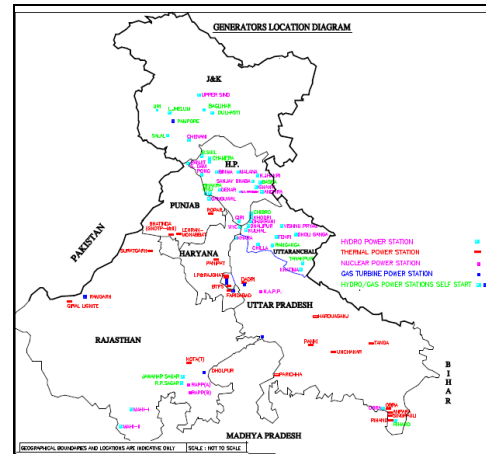

Figure 1.2: Generation in Northern Region

2. Cascade failure due to failure of primary and back up protection

Case-1: This case study discusses about a grid event on 06th July 2005 [3] where a fault on a 400 kV line continued to be fed for 63 minutes due to simultaneous failure of primary and back up protection system. During this event multiple failures occurred simultaneously, resulting in several tripping and substantial loss of supply. The conductor of one of the phases of a 400 kV Muradnagar-Agra line (see figure-2) snapped causing phase to ground fault. Distance protection from 400 kV Agra cleared the fault in zone-1 but the fault could not be cleared from 400 kV Muradnagar due to failure of the operating mechanism (pneumatic) of the SF₆ breaker (Breaker number 96 in Figure-2) at Muradnagar. Local breaker back up of this breaker in 400 kV Muradnagar operated and tripped the bus coupler along with all breakers except the main breaker of the feeder connected to 400 kV Dadri. The trip command to all breakers was sent by Local Breaker Backup (LBB) of Agra line breaker because of the non-functional bus selection logic in the double main transfer scheme (DMT) adopted at 400 kV Muradnagar. As a result the fault on 400 kV Muradnagar-Agra continued to be fed from 400 kV Dadri resulting in severe stress in the system. The fault could have been cleared by tripping of 400 kV Dadri-Muradnagar. However, the fault was beyond the reach of Zone-III as seen from 400 kV Dadri. Thus the fault remained uncleared.

At 400 kV Dadri, the generating units are connected at 220 kV level and switched to 400 kV through 400/220 kV ICTs. The earth fault protection of ICT-3 (see figure-3) operated and the main and tie breakers opened immediately. However, even though the breaker had opened in time, the current sensing relay of one of the breaker failed to reset due to a partially dropped flag. This was therefore seen as a breaker-fail condition resulting in LBB operation, unwanted tripping of multiple breakers and loss of one 400 kV bus. The fault continued to be fed from the grid via the other bus. The four generator transformers connected to this bus tripped on back up earth fault protection. During the event, few other generators tripped either on negative phase sequence protection or on excitation failure or on high turbine vibration. An HVDC bi-pole terminating at 400 kV Dadri tripped on operation of DC harmonic protection and voltage imbalance. The fault was ultimately cleared after Muradnagar breaker of Dadri-Muradnagar line blasted (refer figure-3).

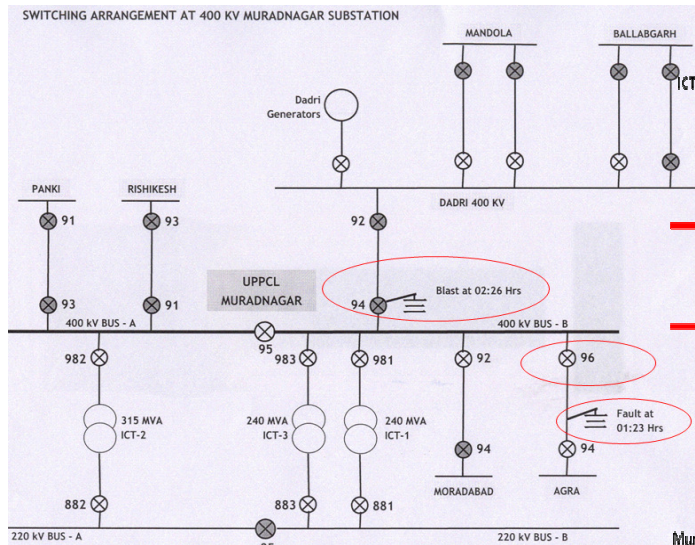

Figure 2: 400 kV Muradnagar schematic

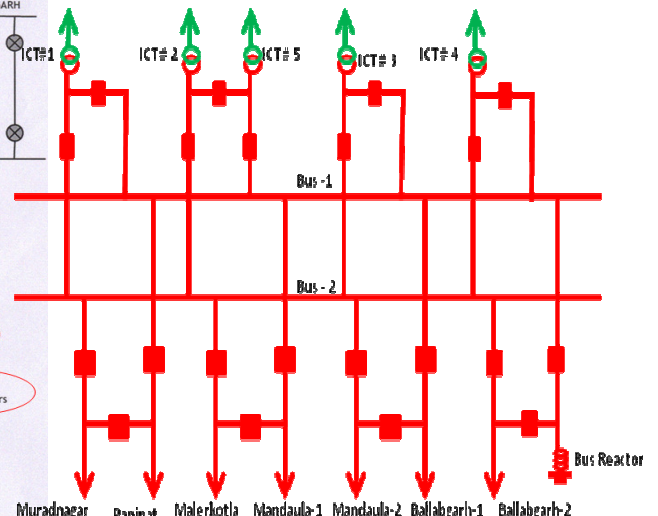

Figure 3: 400 kV Dadri switching diagram

Case-2: On 2nd January 2010, at around 2144 hrs [4], the earth wire of 400 kV Bamnauli-Ballabgarh ckt-II (refer figure 4) snapped and created a high resistance R-phase fault. The R phase pole of the circuit breaker struck at Ballabgarh end and LBB operated to clear the fault from Ballabgarh end. The fault was not cleared from Bamnauli end due to protection/breaker mis-operation and the LBB protection at Bamnauli being out of service. Since the fault resistance was high, the fault was out of reach of zone-2 and zone-3 of remote end (Bawana/Mandaula) distance protection. At remote ends (Mandaula/Bawana) back up earth fault protection was also not provided although it should have been as per the protection philosophy [7]. Thus the fault continued to be fed for about 2 minutes. This caused severe voltage drop around Delhi system and the 4 parallel lines beyond Bawana tripped on backup directional earth fault protection and other several parallel transmission lines in cascade resulting in large generation and load loss.

3. Multiple auto-reclose and line tripping during fog

Case-3: NR generally experiences dense fog during the night and early morning hours in winter season (December to March, ambient temperature < 15° C and relative humidity > 85%). There have been instances of tripping of a large number of Extra High Voltage (EHV) transmission lines in Northern region under such foggy conditions and during this period the network gets depleted and the system is under severe stress. In the past some of the dates on which such events occurred are 02nd January-01, 23rd December-02, 23rd December-05, 12th December-06, 23rd December-06, 27th December-06, 31st December-06, 16th February-06, 27th January-07, 28th January-07, 29th January-07, 01st February-07, 08th February-07, 09th February-07, 01st December-07, 13th December-07, 14th December-07, 07th January-08, 11th January-08, 4th February-08, 5th February-08, 04th March-08, 07th March-08 and 09th March-08. During such events, the transmission line auto-reclose/tripping is generally attributable to pollution related flashover and the number of operations on the EHV switchgear is exceptionally high.

A typical number of switching operations that occurred within a span of few hours on 07th, 08th and 09th March 2008 [5] have been summarized in the table below. The switching arrangement at the 400 kV level is generally one-and half breaker while at 220 kV level it is

double main and transfer scheme (DMT). Therefore, at one end of line, a switching operation for auto-reclosure would involve two operations of generally two breakers (two poles); a switching operation for a tripping would involve operation two breakers (six poles); a switching operation for line restoration would involve two breakers (six poles) and considering both ends of line, the operations would be double of this. However, only one operation has been considered each for tripping/restoration/auto-reclosing of a line while reporting the switching operations in the table 1.

Table 1: Number of switching operation on 07, 08 and 09th Mar-2008

Date	07 th March 2008			08 th / 09 th March 2008		
Duration	17 hours			21 hours		
Voltage level (kV)	400 kV & above	220 kV	Total	400 kV & above	220 kV	Total
Number of lines affected	50	154	204	40	101	141
Particulars	A	B	C = A + B	E	F	G = E + F
Number of auto-reclose operations	60	0	60	95	1	96
Number of tripping	88	203	291	76	101	177
Number of switching operation for line restoration	86	204	290	74	101	175
Total number of switching operations	234	407	641	245	203	448

A large number of switching operations within a short span of time may cause stress on the switchgear leading to wear and tear and even the fear of mis-operations. However, for system reliability and keeping integrity, successful auto-reclose of line for transient fault and quick revival of lines after trip are vital under such extreme weather conditions and therefore allowed. Learning from such incidents auto reclose feature is now being enabled on rest of 220 kV transmission lines as well. Further, porcelain insulators are being changed with polymer ones to avoid such large scale auto-reclosing and tripping.

4. Cascade failure due to incorrect setting in numerical relay

In India the protection system is gradually being upgraded from the electro mechanical/static relays to microprocessor based numerical relays. The numerical relays have inherent advantages over the conventional electro mechanical/static relays and therefore, gradually the numerical relays are being adopted all across the system. However many a times the incorrect settings in the numerical relays have also become a cause of failure. The next three cases discuss the unintended operation involving numerical relays.

Case-4: This case discusses the performance of distance relay when the system was under stress due to planned outage of one of the circuits of a double circuit line and forced outage of the other circuit. The city of Delhi has a 400 kV ring main system comprising of 400 kV double circuit lines with quad bersimis conductor configuration (refer figure 4). On 12th October 2007 [6], this ring main system opened due to planned outage of 400 kV Mandaula-Bawana-II followed by forced outage of 400 kV Mandaula-Bawana-I. The antecedent flow on the 400 kV Mandaula-Bawana-I was 1065 MW. Consequently the power diverted on 400 kV Mandaula-Dadri-Ballabgarh-Bamnauli-Bawana section followed by unintended tripping of several 400 kV circuits. This caused tripping of other parallel tie lines in cascade resulting in load loss of more than 9GW. Upon investigation it was found that the cascade was initiated by tripping of 400 kV Mandaula-Bawana-I that tripped on misoperation of carrier protection. This was followed by tripping of four 400 kV circuits because of unintended and default

setting of the over current element (set at 1kA) in the numerical line protection relay though such over current element should have been disabled as per protection philosophy [7].

The cascade tripping on 12th October 2007 resulted in isolation of large subsystem situated in the North-western part of the grid, which collapsed due to mismatch of generation-load and inadequate relief from under frequency as well as df/dt load shedding scheme. Upon examination it was also understood that in the numerical relays of certain make, multiple protection starting triggers are provided and there is no provision of disabling any of them. Further, since large number of provisions are made in numerical relays, many a time Commissioning Engineers leave many setting on default due to time constraints or inadequate understanding of the consequences such left over settings.

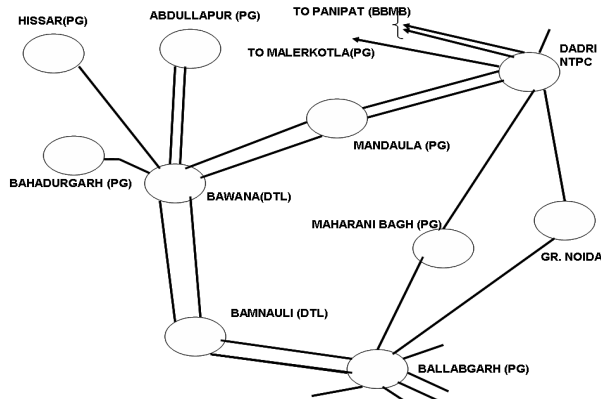

Figure 4: Sketch of 400 kV Delhi ring main system

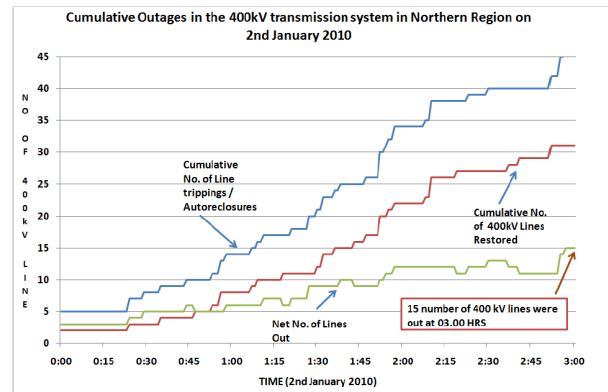

Figure 5: Cumulative number of lines tripped or restored during 0000 to 0300 hrs of 02nd Jan-2010

Case-5: Another cascade failure occurred during morning hours of 02nd January 2010 [4] due to unintended setting of over current element in numerical relay on one of the newly commissioned 400 kV lines causing system separation. On that day the network was depleted due to tripping of a large numbers of 220 kV and 400 kV lines particularly in the North-West part of the region due to fog. There was an unintended and unexpected operation of over current protection on the vital interstate tie-line between subsystem comprising of load centre in the Punjab/ North Haryana/Himachal Pradesh/Jammu and Kashmir system and the rest of the grid. Consequently the subsystem isolated and collapse due to mismatch between load-generation, inadequate primary response and inadequate relief from under frequency load shedding scheme.

The incidents of 12th Oct-07 and 02nd Jan-10 highlight the misoperations involving numerical relays. These relays are micro processor based and are capable of offering diverse protection schemes within a single relay. The process for configuring a relay for a particular scheme is also simple but the chances for human errors occurring due to inadequate understanding of the operation philosophy of the relay amongst the commissioning engineers as well as utility engineers also is very high. Such errors are detected only when network is under stress.

5. Conclusion

It is well established that a reliable, well designed and meticulously coordinated protection system is a prerequisite for secure operation of an electricity grid. However, continuously changing network/network augmentation due to high growth rate, changing business environment and the organizational set up in utilities is throwing up protection coordination as a challenge involving large number of utilities. The turnover in human resource has also increased with aging workforce and opening up of the sector that is creating newer opportunities for experienced engineers in the private sector. The renovation and

modernization drive is leading to deployment of new technology in place of the older technology. Therefore, business strategy, operating protocols as well as engineering practices in the utilities are being realigned under the influence of the new regulatory guidelines and pressure of competition.

The various issues highlighted in the paper need to be viewed from the perspective of a developing country. In order to address the system security concerns protection audit of substations is being discussed and actively being pursued in India. The aim of the audit is to review the protection philosophy, relay coordination and protection settings, healthiness of DC system, healthiness of communication link with respect to protection system, healthiness of Time Synchronization Units, healthiness of disturbance recorders and event loggers, protection testing procedures and protection system technology.

It is also important that the utilities as well the vendors need to pay more attention to sharing of knowhow and towards capacity building of human resource particularly in the area of power system protection. Preferably a system of certification of engineers working in the area of protection testing and commissioning could be established. This would help in improving the capability of the workforce and enhance the performance of protection system.

Acknowledgement

The authors would like to acknowledge immense contribution made by each and every member of the various inquiry committees set up to investigate the grid incidents. The detailed report has provided excellent insight into the grid incident and helped in documenting the issues highlighted in this paper. The authors would like to thank the management of Power Grid Corporation of India Limited and Power System Operation Corporation Limited for their encouragement and support. The technical support and cooperation extended by subordinates, colleagues and engineers in the substations and generating stations is also gratefully acknowledged.

References

- [1] Central Electricity Regulatory Commission (Indian Electricity Grid Code), Regulations 2010; <http://cercind.gov.in/Regulations/Signed-IEGC.pdf>
- [2] Central Electricity Authority (Grid Standards), Regulation, 2010; http://www.cea.nic.in/reports/regulation/grid_standards_reg.pdf
- [3] CEA, 'Report of the Committee on Grid Incident in NR on 6th July 2005', August 2005; <http://www.nrpc.gov.in/reports/enq/06Jul2005.pdf>
- [4] Central Electricity Authority (CEA), 'Report of the Inquiry committee on Grid Disturbance in NR on 2nd January 2010'; <http://www.nrpc.gov.in/reports/enq/02Jan2010.pdf>
- [5] CEA, 'Report of the Inquiry Committee on Grid Incident in NR on 07th and 09th March 2008', December 2008; <http://www.nrpc.gov.in/reports/enq/07-09Mar2008.pdf>
- [6] CEA, Report of the Inquiry Committee on Grid Incident in NR on 12th October 2007; <http://www.nrpc.gov.in/reports/enq/12Oct2007.pdf>
- [7] Central Board of Irrigation and Power, 'Manual on Reliable Fault Clearance and Back-up Protection of EHV and UHV Transmission Networks' September 2005
- [8] Central Board of Irrigation and Power, 'Manual on Protection of Generators, Generator Transformers and 220 kV and 400 kV Networks, November, 1999